

EGPL-21S3

M.2 2230 to Single Isolated 2.5GbE LAN Module

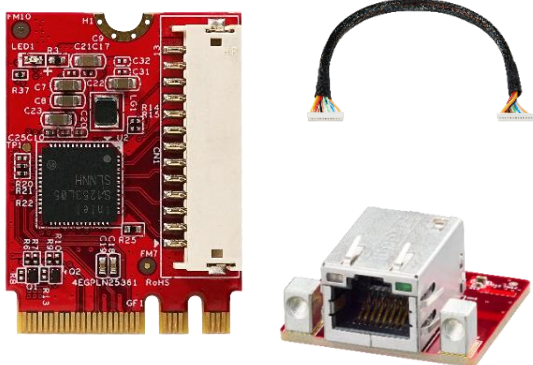

HIGHLIGHT FEATURES

- Intel i226 controller
- Complies with IEC 60950-1 : 2005 + A1 : 2009 + A2 : 2013 2kV HiPOT protection
- Complies with EN61000-4-2 (ESD) Air-15kV, Contact-8kV
- Flexible daughter board with cable to fit into different system
- Optional industrial temperature (-40°C to 85°C) support
- Industrial design, manufactured in Innodisk Taiwan

SPECIFICATIONS

Model Name	EGPL-21S3
Module Type	M.2 2230 to Single Isolated 2.5GbE LAN Module
Form Factor	M.2 2230 A+E Key
Function	LAN
Input I/F	PCI Express 2.1 x1
Output I/F	2.5GbE LAN
Output Port	1
Output Connector	RJ45
Max. Power Consumption	1.072W (3.3V, 325mA)
Dimension (W x L x H/mm)	Main Board : 22 x 30 x 5.95 Daughter Board : 32x 28 x 19.2
Temperature	Operation : S/T 0°C ~ 70°C ; W/T -40°C ~ 85°C (Ta) Storage : -55°C ~ 95°C (Ta)
Vibration	5G@[7~2000Hz]
Shock	50G@0.5ms
OS Support	Windows : 10 (64bit), and above version Linux (igc) : Kernel 5.16.18
Warranty	3 Years
Notes	<ul style="list-style-type: none"> • Please download Windows driver from Intel official website. • Linux upstream kernel release from 5.16.18 (inbox igc driver)

ORDER INFO.

P/N	Description
EGPL-21S3-C1	M.2 2230 to Single Isolated 2.5GbE LAN Module, Mounting Hole / Standard Temperature
EGPL-21S3-W1	M.2 2230 to Single Isolated 2.5GbE LAN Module, Mounting Hole / Wide Temperature

MECHANICAL DRAWING

Main Board

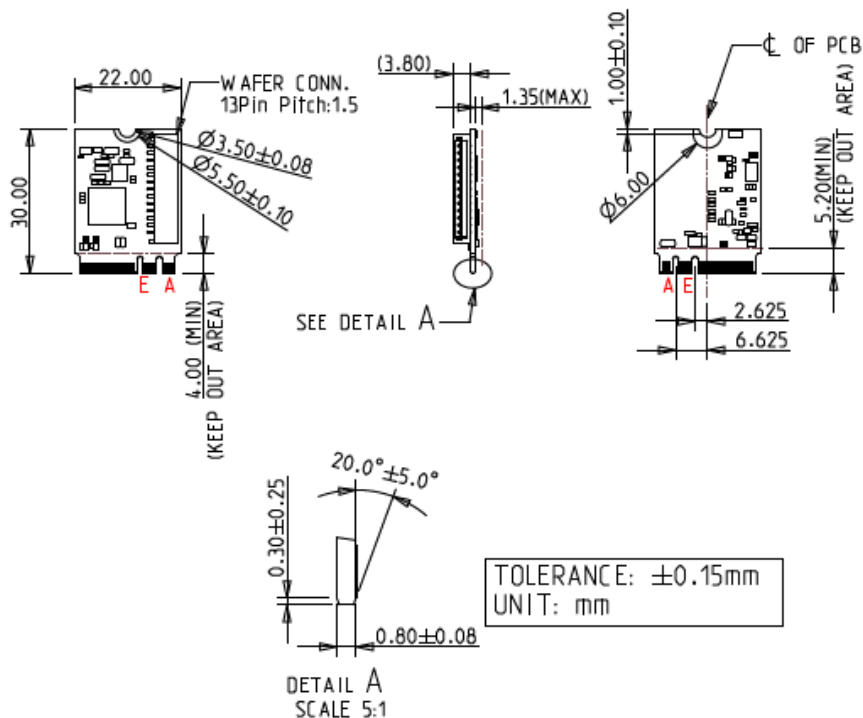

Daughter Board

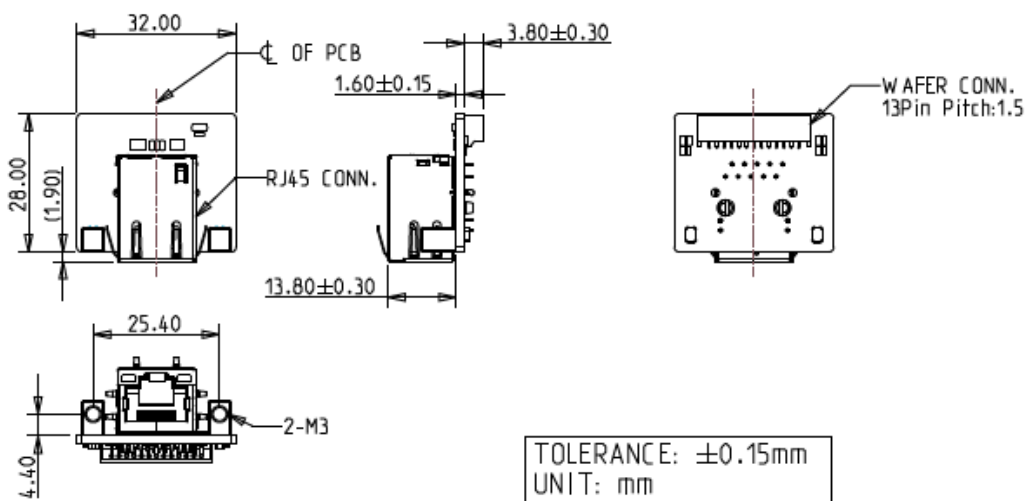

HQ (Taiwan) T +886-2-7703-3000 / E sales@innodisk.com

CN T +86-755-2167-3689 / E sales_cn@innodisk.com

US T +1-510-770-9421 / E usasales@innodisk.com

EU T +31-40-3045-400 / E eusales@innodisk.com

JP T +81-3-6667-0161 / E jp_sales@innodisk.com

innodisk