

EGPL-T2F1

M.2 2242/2280 to dual 10 GbE SFP+ LAN Module

HIGHLIGHT FEATURES

- Intel X710-BM2 Ethernet Controller
- Supports common 10GbE SFP+ Optical and direct attached Copper modules
- Support DPDK 16.11
- Support PTP (IEEE 1588-2008 (PTPv2) hardware timestamping)
- SR-IOV support up to 128VFs shared across 2 ports
- Flexible daughter board with cable to fit into different system
- With high speed shielding coaxial cable and standard PCIe bracket

SPECIFICATIONS

Model Name	EGPL-T2F1
Module Type	M.2 to Dual 10GbE SFP+ LAN Module
Form Factor	M.2 2242 M Key / M.2 2280 M Key
Function	Fiber Optical SFP+
Input I/F	PCIe Gen 3 x4
Output I/F	10GbE Fiber Optical
Output Port	2
Output Connector	SFP
Max. Power Consumption	10.1W (3.3V, 3060mA)
Dimension (W x L x H/mm)	M.2 Board : W1 : 22 x 42 x 2.24 ; W2 : 22 x 80 x 2.24 Daughter Board : 70 x 95 x 1.6
Temperature	Operation : S/T 0°C ~ 55°C (Ta) Storage : -40°C ~ 70°C (Ta)
Vibration	5G@[7~2000Hz]
Shock	50G@0.5ms
OS Support	Windows : 10 (64bit) and above versions Linux (igc) : Kernel 3.16 and above versions
Warranty	3 Years
Notes	-

ORDER INFO.

P/N	Description
EGPL-T2F1-C1	M.2 2280 to Dual 10GbE SFP+ LAN Module
EGPL-T2F1-C2	M.2 2242 to Dual 10GbE SFP+ LAN Module

MECHANICAL DRAWING

Main Board

EGPL-T2F1-C1 (2280)

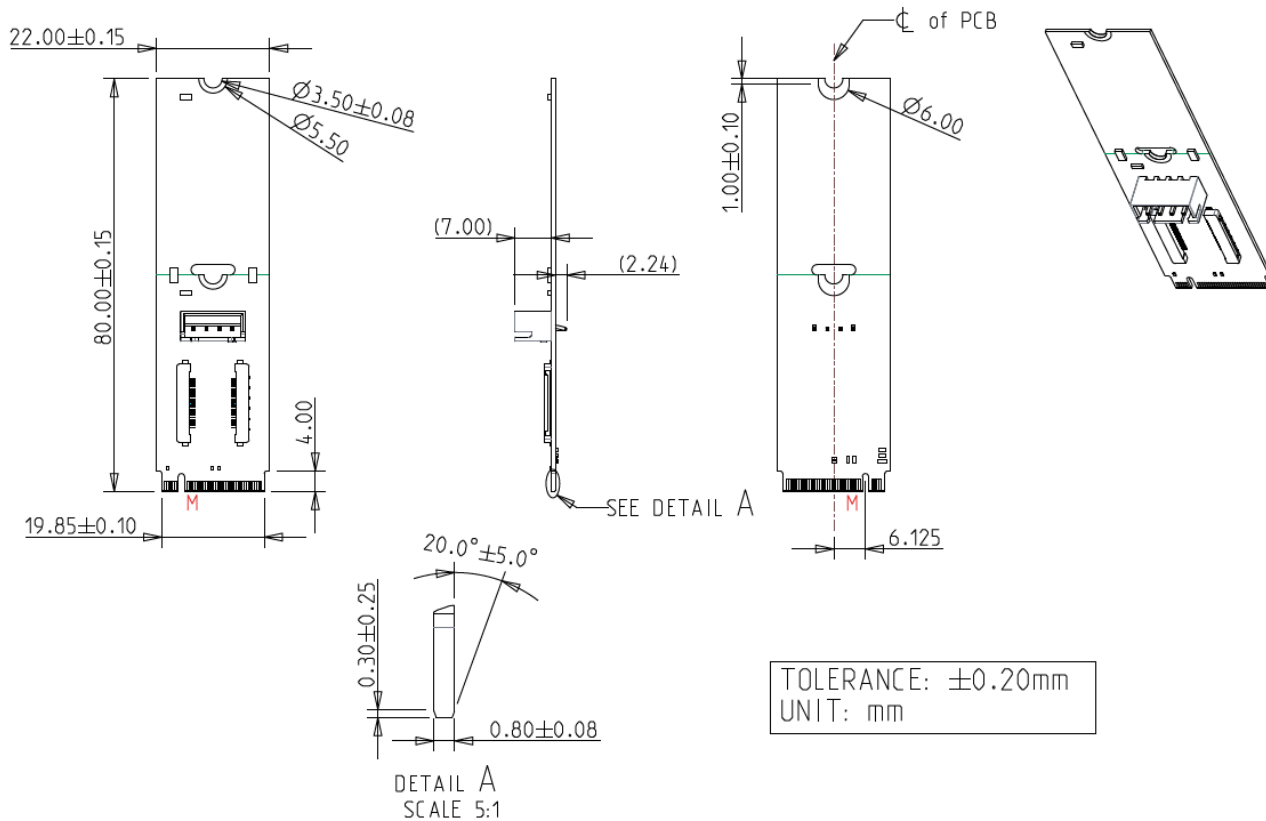

EGPL-T2F1-C2 (2242)

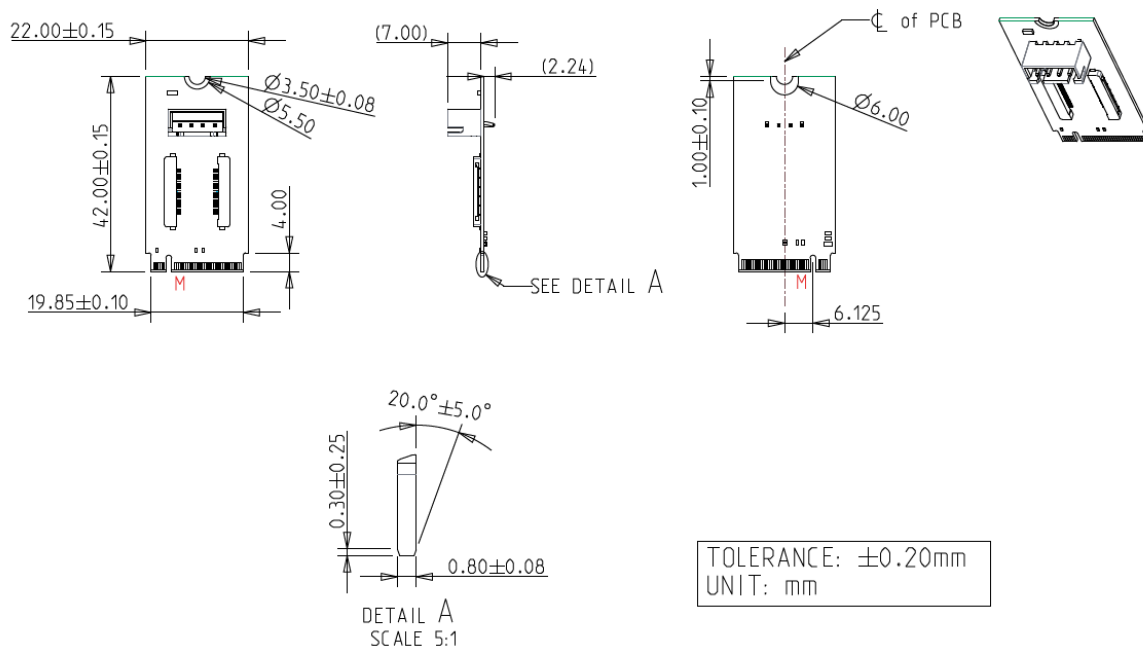

MECHANICAL DRAWING

Daughter Board 2 Port SFP Board

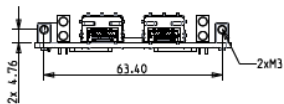
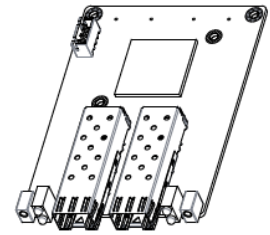
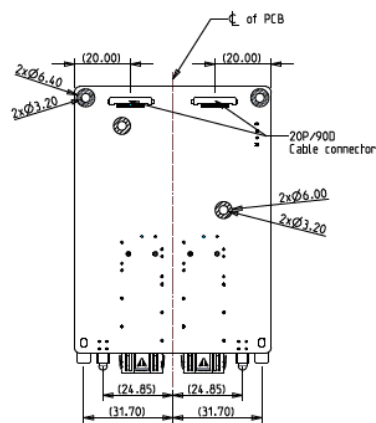
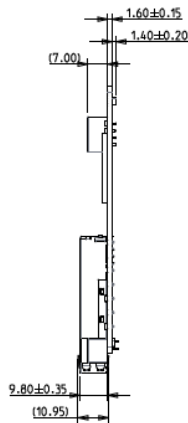
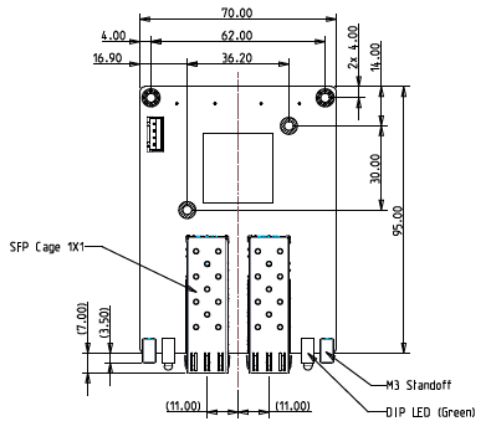

TOLERANCE: ±0.30mm
UNIT: mm

2 Port SFP Board, with Bracket

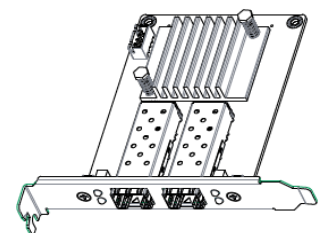
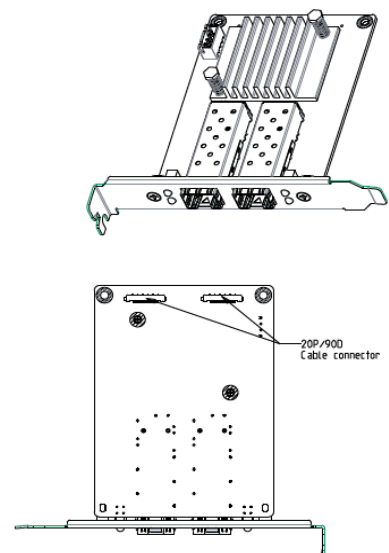
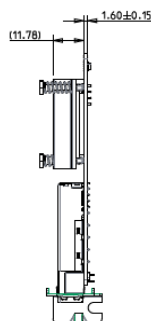
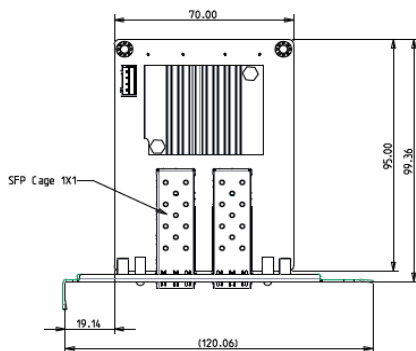

TOLERANCE: ±0.30mm
UNIT: mm

HQ (Taiwan) T +886-2-7703-3000 / E sales@innodisk.com

CN T +86-755-2167-3689 / E sales_cn@innodisk.com

US T +1-510-770-9421 / E usasales@innodisk.com

EU T +31-40-3045-400 / E eusales@innodisk.com

JP T +81-3-6667-0161 / E jp_sales@innodisk.com

